



Apollo2 Product Overview

AUGUST 2009

Apollo2 Monitor Arms

OUR SLIMLINE RANGE

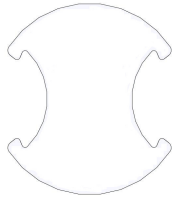

Enjoy the immediate productivity, ergonomic and space benefits with our Apollo2 slimline post range. Featuring two Integ slots or grooves, the Apollo2 post range can be secured to your desk with our slimline post and either a split clamp or grommet mount.

Idea Applications

The key component to the Apollo2 is a post with two (2) unique grooves that connect the arm(s) and accessories to the mounting mechanism. Two (2) slots means up to two monitor or accessory arms can be added.

The Apollo2 slimline range is ideal for call centres, home offices and single screen users. The modular nature of the solution still allows a second screen or laptop tray to easily be added within minutes.

This slot ensures the monitor arms needs only one tool to install (a factory supplied Allen key) or adjust and it contains no mechanical parts that can break down.

THE APOLLO2 MONITOR ARM PROVIDES THE FOLLOWING BENEFITS:

- 12 kg weight load for the pole (either one monitor of 12 kg's or 2 x 6kg's monitors)
- Durable powder coated finish, diecast / powder coated zinc, aluminium alloy and steel components
- Adjustable Grommet or split clamp mounting options suitable for a wide range of desk thicknesses
- Our quick release VESA plate allowing the monitor to be released in seconds
- Time to assemble - less than 5 minutes
- 5 year warranty
- Laptop tray, ideal for touch down or hot desk stations

Material Content

Our monitor arms have been designed with disassembly and durability in mind, reducing environmental impacts over a longer period of time.

MODTEC INDUSTRIES ARE WINNERS OF THE FOLLOWING ENVIRONMENTAL AWARDS

NZ Recycling Award 1999

PRODUCT CONTENT (CLASSIC A2-4S2G MODEL)

Aluminium Content	14%
Zinc Alloy	77%
Plastic	1%
Steel	8%

Packaging material includes bulk packed with cardboard, egg trays and plastic poly protective bags. Modtec encourages you to recycle.

Our monitor arm is 99% recyclable at the end of its useful live. All parts can be returned to Modtec Industries for recycling.

Apollo2 Classic Configurations

PRODUCT CODE IMAGE

A2-4S2D

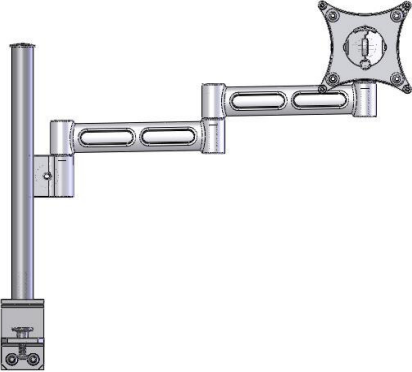

DESCRIPTION

Apollo2, 400mm pole, 2-limb arm front-loading wedge with finger friendly side access adjustment, quick release VESA plate and split clamp. Capacity – 12 kg per arm, 12kg per pole.

The number of arms and reach of the arms are modular in nature and can be re-configured as users or technology requirements change.

OPTIONS

- 360° VESA plate
- Grommet mount
- Laptop tray

SPECIFICATIONS

Arm Reach	528 mm
Monitor Pivot	145°
Horizontal Adjustment	360°
Vertical Adjustment	350 mm
Cable Management	Included
Maximum screen weight	12 kg's per arm

PRODUCT CODE IMAGE

A4-4D2G

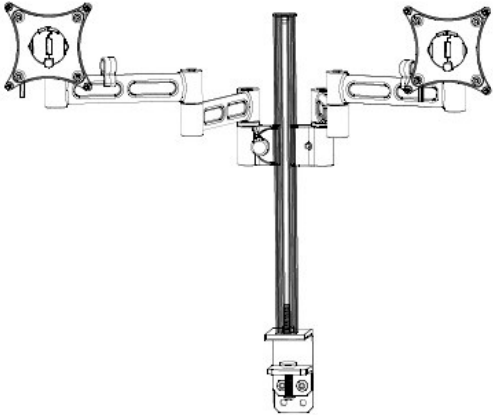

DESCRIPTION

Apollo2, 400mm pole, 2 x 2-limb arm front-loading wedge with finger friendly side access adjustment, quick release VESA plate and split clamp. Capacity – 12 kg per arm, 12kg per pole.

The number of arms and reach of the arms are modular in nature and can be re-configured as users or technology requirements change.

OPTIONS

- 360° VESA plate
- Grommet mount
- Laptop tray

SPECIFICATIONS

Arm Reach	528 mm
Monitor Pivot	145°
Horizontal Adjustment	360°
Vertical Adjustment	350 mm
Cable Management	Included
Maximum screen weight	12 kg's per arm, 12 kg for the pole

Specifications

FEATURE

IMAGE

Monitor Pivot & Adjustment

Truly with **145 degree** tilt &

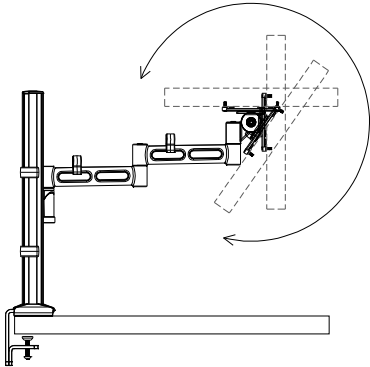

180 degree horizontal pivot & adjustment

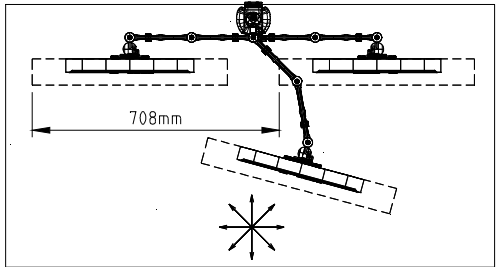
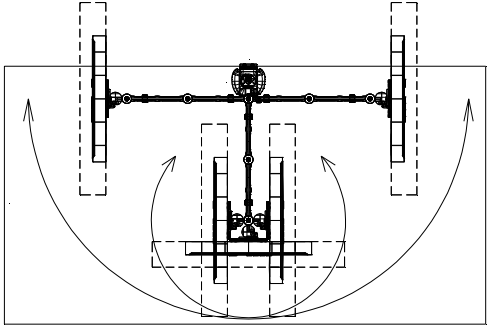

FEATURE

IMAGE

Double screen set up with **680mm** screen width

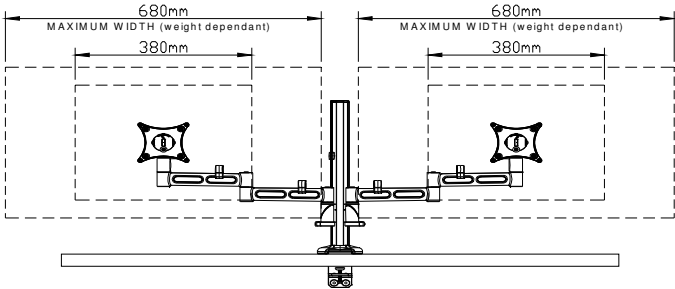

Three-screen set up with **380mm** screen width.

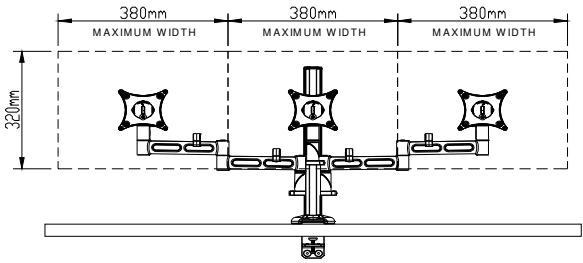
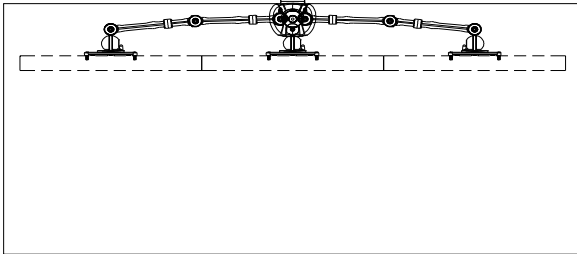

About Integ

Integ is a manufacturer and designer of modular monitor arms and office accessories. Proudly made in New Zealand by Modtec Industries, our difference lies in our range of modular components, which come together to deliver unique mounting solutions. This Lego® styled approach drives our design philosophy from idea to product installation.

To learn more about Integ, our people and our products please visit www.integinternational.com or email us on helpme@integinternational.com

MODTEC INDUSTRIES SUPPORTS THE FOLLOWING LOCAL INITIATIVES.

